

2

1

B

B

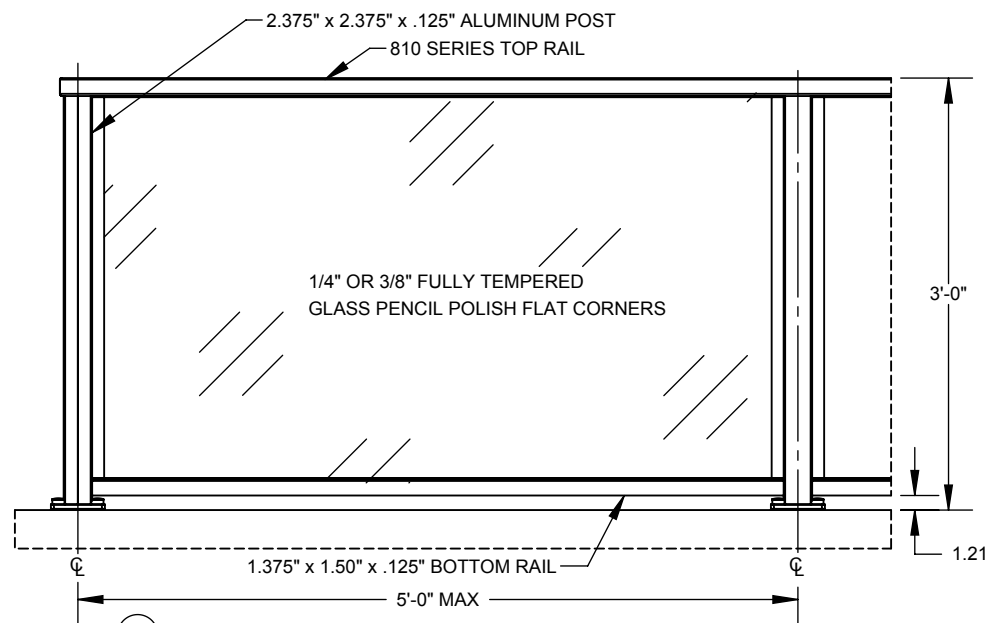

1 GLASS WITH TOP & BOTTOM RAIL, DECK MOUNT

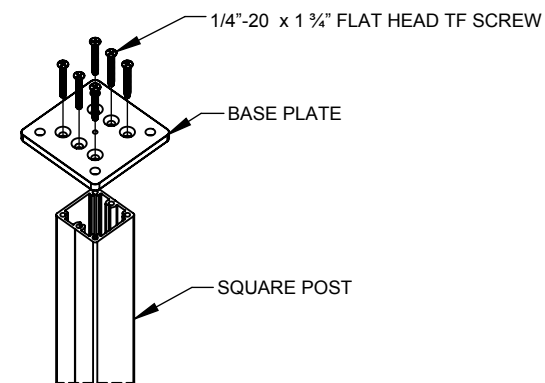

2 TYP. BASE PLATE TO POST CONNECTION
SCALE 1 : 8

A

A

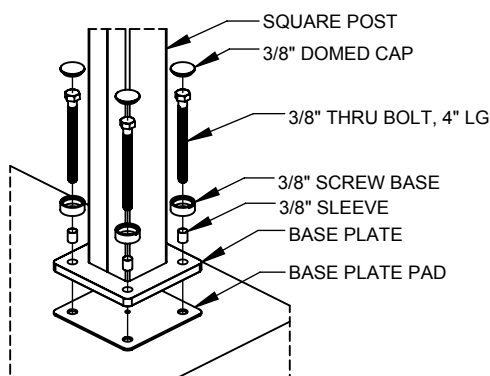

3 TYP. DECK MOUNTING CONNECTION
SCALE 1 : 8

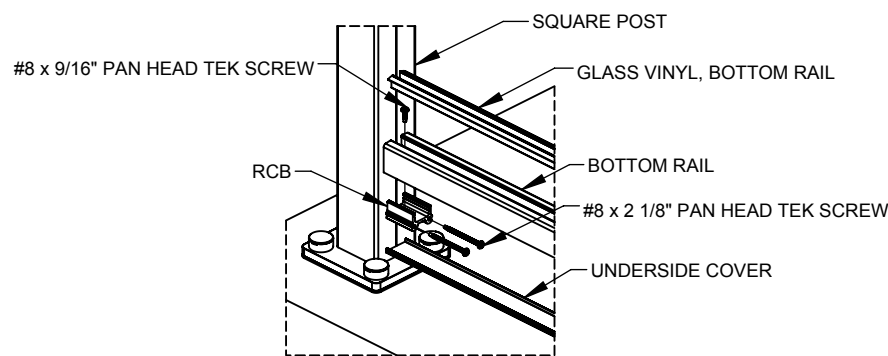

4 TYP. BOTTOM RAIL CONNECTION
SCALE 1 : 8

eGlass Solid™

PROPRIETARY AND CONFIDENTIAL

THE INFORMATION CONTAINED IN THIS DRAWING IS THE SOLE PROPERTY OF EGLASS LLC. ANY REPRODUCTION IN PART OR AS A WHOLE WITHOUT THE WRITTEN PERMISSION OF EGLASS LLC IS PROHIBITED.

NOTES: UNLESS OTHERWISE SPECIFIED

1. DIMENSIONS SHOWN - INCHES [MM].
2. MACHINED SURFACES TO BE 63UIN MAX.
3. PART TO BE FREE OF BURRS AND SHARP EDGES.
4. ALL MATERIAL TO BE CLEAN, DEGREASED AND FREE OF ALL IMPURITIES.
5. ANY CHANGE MUST BE AUTHORIZED BY AN EGLASS ENGINEER.

DIMENSIONS ARE IN INCHES
FRACTIONAL ±
ANGULAR: MACH ±
TWO PLACE DECIMAL ±
THREE PLACE DECIMAL ±

MATERIAL
FINISH
DO NOT SCALE DRAWING

	NAME	DATE
DRAWN	V.P.	08/07/18
ENG APPR.		
MFG APPR.		

COMMENTS:
PURCHASER HAS THE FULL RESPONSIBILITY TO COMPLY WITH LOCAL, NATIONAL AND INTERNATIONAL BUILDING CODES. PURCHASER SHALL COMPLY IN ALL RESPECTS WITH ALL APPLICABLE LEGAL REQUIREMENTS GOVERNING THE DUTIES, OBLIGATIONS, AND BUSINESS PRACTICES OF THEIR LOCALITIES AND SHALL OBTAIN ANY PERMITS OR LICENSES NECESSARY FOR THEIR OPERATIONS.



TITLE:
EGLASS SOLID, DECK MOUNT, FLAT DECK, 36" RAILING SYSTEM

SIZE	DWG. NO.	REV
A	RSDF-00-00	5
SCALE: 1:16	WEIGHT:	SHEET 1 OF 3

2

1

2

1

B

B

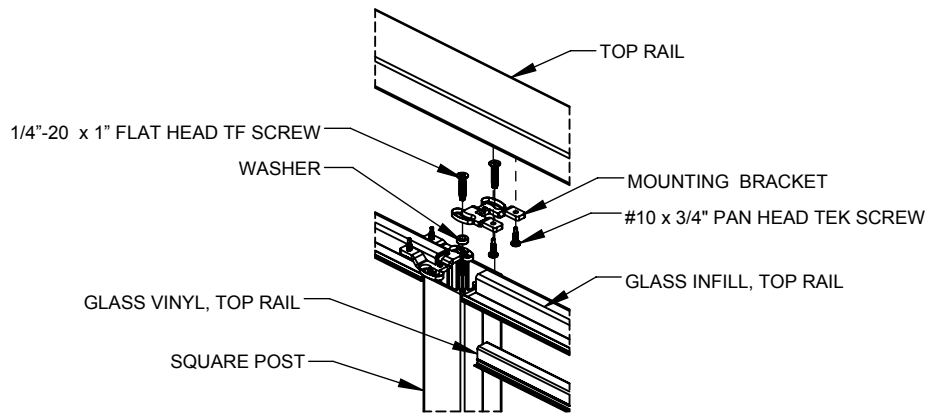

5 TYP. TOP RAIL CONNECTION

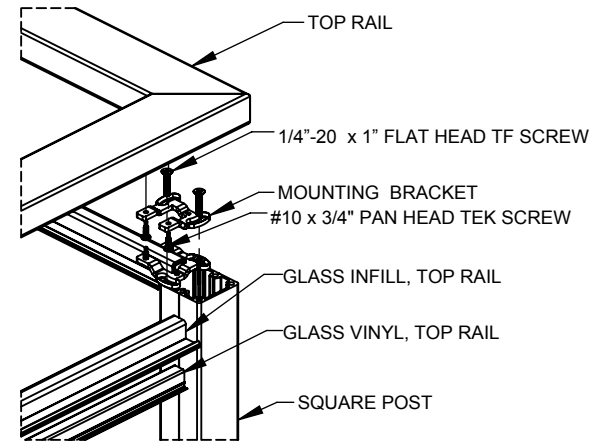

6 TYP. CORNER CONNECTION

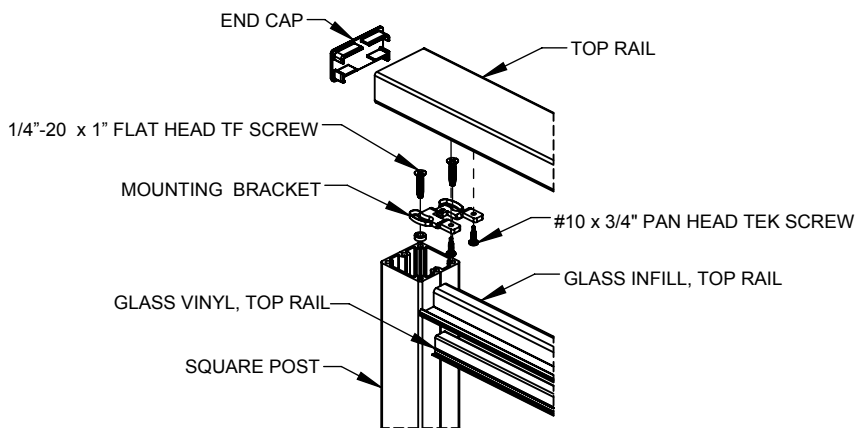

7 END CONDITION DETAIL

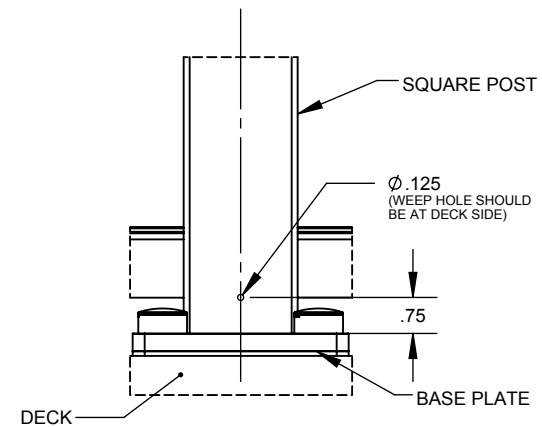

8 TYP. WEEP HOLE

SCALE 1 : 4

A

A

eGlass Solid™

PROPRIETARY AND CONFIDENTIAL

THE INFORMATION CONTAINED IN THIS DRAWING IS THE SOLE PROPERTY OF EGLASS LLC. ANY REPRODUCTION IN PART OR AS A WHOLE WITHOUT THE WRITTEN PERMISSION OF EGLASS LLC IS PROHIBITED.

NOTES: UNLESS OTHERWISE SPECIFIED

1. DIMENSIONS SHOWN - INCHES [MM].
2. MACHINED SURFACES TO BE 63µIN MAX.
3. PART TO BE FREE OF BURRS AND SHARP EDGES.
4. ALL MATERIAL TO BE CLEAN, DEGREASED AND FREE OF ALL IMPURITIES.
5. ANY CHANGE MUST BE AUTHORIZED BY AN EGLASS ENGINEER.

DIMENSIONS ARE IN INCHES
 FRACTIONAL ±
 ANGULAR: MACH ±
 TWO PLACE DECIMAL ±
 THREE PLACE DECIMAL ±

MATERIAL

FINISH

DO NOT SCALE DRAWING

	NAME	DATE
DRAWN	V.P.	08/07/18
ENG APPR.		
MFG APPR.		

COMMENTS:
 PURCHASER HAS THE FULL RESPONSIBILITY TO COMPLY WITH LOCAL, NATIONAL AND INTERNATIONAL BUILDING CODES. PURCHASER SHALL COMPLY IN ALL RESPECTS WITH ALL APPLICABLE LEGAL REQUIREMENTS GOVERNING THE DUTIES, OBLIGATIONS, AND BUSINESS PRACTICES OF THEIR LOCALITIES AND SHALL OBTAIN ANY PERMITS OR LICENSES NECESSARY FOR THEIR OPERATIONS.



TITLE:
EGLASS SOLID, DECK MOUNT, FLAT DECK, 36" RAILING SYSTEM

SIZE	DWG. NO.	REV
A	RSDF-00-00	5

SCALE: 1:8	WEIGHT:	SHEET 2 OF 3
------------	---------	--------------

2

1

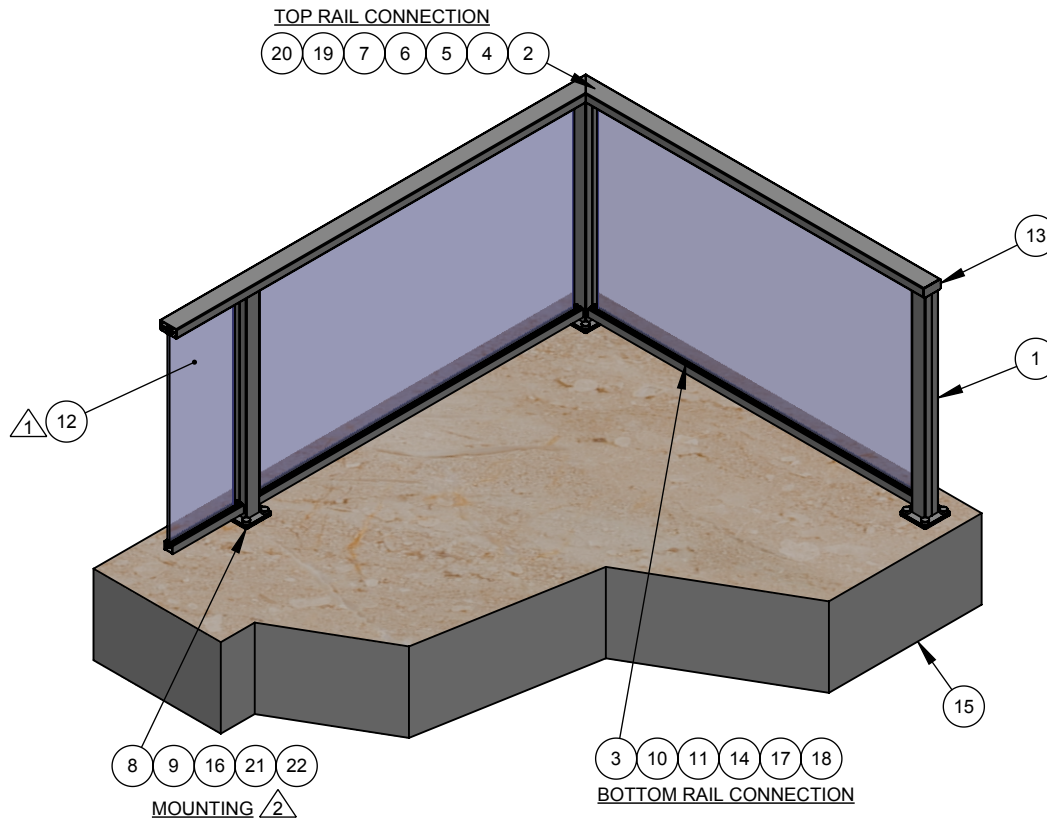

BILL OF MATERIAL TABLE			
ITEM NO.	PART NUMBER	DESCRIPTION	QTY.
1	RADF-SP-36	SQUARE POST, SHORT BLANK, (2 3/8" x 2 3/8" x 1/8" x 36")	AS REQD.
2	810S-TR-01	810 SERIES, TOP RAIL (3" x 1 1/2" x 1/8"), 20' LENGTH	AS REQD.
3	AAAA-BR-01	BOTTOM RAIL (1 3/8" x 1 1/2" x 1/8"), 20' LENGTH	AS REQD.
4	AAAA-TV-31	GLASS VINYL, TOP RAIL, 3/8" THICK GLASS	AS REQD.
5	ASAA-TI-01	EGLASS SOLID, INFILL, TOP RAIL, 20' LENGTH	AS REQD.
6	ASAA-MB-01	EGLASS SOLID, MOUNTING BRACKET	AS REQD.
7	ASAA-WS-01	WASHER	AS REQD.
8	RADA-PD-01	BASE PLATE PAD, SQUARE POST	AS REQD.
9	RADA-BP-01	BASE PLATE, 36" HEIGHT SQUARE POST	AS REQD.
10	AAAA-RC-01	RCB, 1.5" PRE-CUT	AS REQD.
11	AAAA-BV-31	GLASS VINYL, BOTTOM RAIL, 3/8" THICK GLASS	AS REQD.
12	RAAF-G3-56	3/8" TEMPERED GLASS, DECK RAILING	AS REQD.
13	ASAA-EC-01	EGLASS SOLID, END CAP, TOP RAIL	AS REQD.
14	AAAA-UC-01	BOTTOM RAIL, UNDERSIDE COVER, 20' LENGTH	AS REQD.
15	STD-DK-01	CONCRETE DECK	AS REQD.
16	STD-AC-01	3/8" THRU BOLT, 4" LG	AS REQD.
17	STD-SC-01	#8 x 2 1/8" PAN HEAD TEK SCREW	AS REQD.
18	STD-SC-02	#8 x 9/16" PAN HEAD TEK SCREW	AS REQD.
19	STD-SC-03	#10 x 3/4" PAN HEAD TEK SCREW	AS REQD.
20	STD-SC-04	1/4"-20 x 1" FLAT HEAD TF SCREW	AS REQD.
21	STD-SC-05	1/4"-20 x 1 1/4" FLAT HEAD TF SCREW	AS REQD.
22	STD-SW-00	3/8" SCREW COVER	AS REQD.

NOTES:

- 1 DIFFERENT SIZES OF GLASS PANELS ARE AVAILABLE. REFER DWG NO: RAAF-G2-08 (1/4" THK) AND RAAF-G3-08 (3/8" THK).
- 2 MOUNTING:

FOR CONCRETE:

- 1. STD-AC-01 (3/8" THRU BOLT, 4" LENGTH)

FOR WOOD:

- 1. STD-AC-03 (3/8" LAG SCREW W/MIN 6" EMBED)

<p>NOTES: UNLESS OTHERWISE SPECIFIED</p> <p>1. DIMENSIONS SHOWN - INCHES [MM]. 2. MACHINED SURFACES TO BE 63UIN MAX. 3. PART TO BE FREE OF BURRS AND SHARP EDGES. 4. ALL MATERIAL TO BE CLEAN, DEGREASED AND FREE OF ALL IMPURITIES. 5. ANY CHANGE MUST BE AUTHORIZED BY AN EGLASS ENGINEER.</p>		<p>DIMENSIONS ARE IN INCHES</p> <p>FRACTIONAL ± ANGULAR: MACH ± TWO PLACE DECIMAL ± THREE PLACE DECIMAL ±</p>		<p>NAME</p> <p>V.P.</p>	<p>DATE</p> <p>08/07/18</p>	<p>EGLASS RAILING™</p> <p>TITLE: EGLASS SOLID, DECK MOUNT, FLAT DECK, 36" RAILING SYSTEM</p>	
		<p>MATERIAL</p> <p>FINISH</p> <p>DO NOT SCALE DRAWING</p>		<p>COMMENTS: PURCHASER HAS THE FULL RESPONSIBILITY TO COMPLY WITH LOCAL, NATIONAL AND INTERNATIONAL BUILDING CODES. PURCHASER SHALL COMPLY IN ALL RESPECTS WITH ALL APPLICABLE LEGAL REQUIREMENTS GOVERNING THE DUTIES, OBLIGATIONS, AND BUSINESS PRACTICES OF THEIR LOCALITIES AND SHALL OBTAIN ANY PERMITS OR LICENSES NECESSARY FOR THEIR OPERATIONS.</p>			
<p>eGlass Solid™</p> <p>PROPRIETARY AND CONFIDENTIAL</p> <p>THE INFORMATION CONTAINED IN THIS DRAWING IS THE SOLE PROPERTY OF EGLASS LLC. ANY REPRODUCTION IN PART OR AS A WHOLE WITHOUT THE WRITTEN PERMISSION OF EGLASS LLC IS PROHIBITED.</p>		<p>SCALE: 1:24</p>		<p>WEIGHT:</p>		<p>SHEET 3 OF 3</p>	