

2

1

B

B

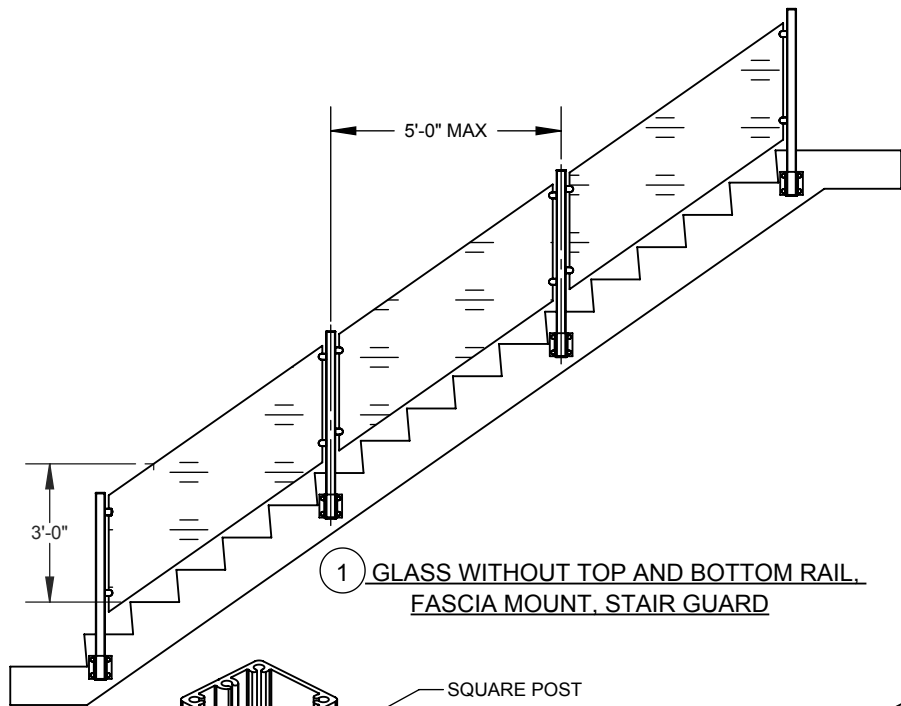

1 GLASS WITHOUT TOP AND BOTTOM RAIL, FASCIA MOUNT, STAIR GUARD

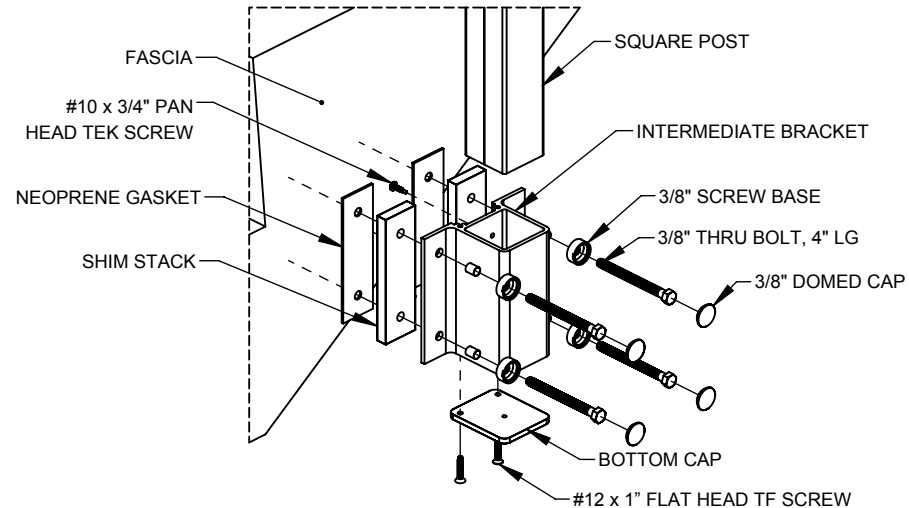

2 TYP. POST TO DECK CONNECTION  
SCALE 1:8

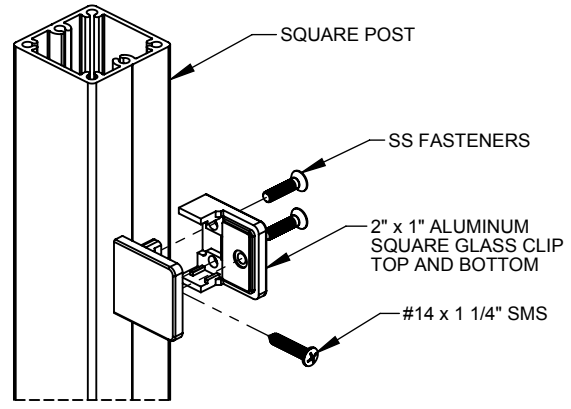

OPTION-1  
SCALE 1:4

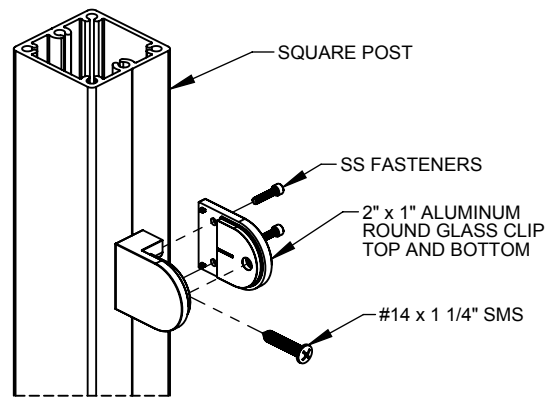

OPTION-2  
SCALE 1:4

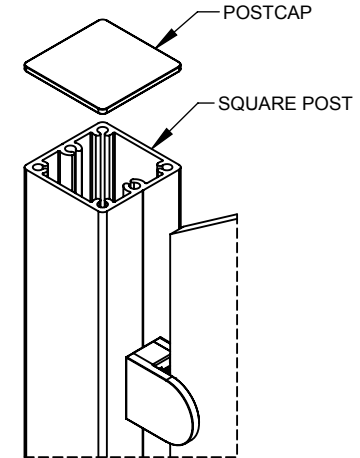

4 TYP. POSTCAP TO SQUARE POST  
SCALE 1:4

3 POST-CLIP CONNECTION

A

A

eGlass Vision™

PROPRIETARY AND CONFIDENTIAL

THE INFORMATION CONTAINED IN THIS DRAWING IS THE SOLE PROPERTY OF EGLASS LLC. ANY REPRODUCTION IN PART OR AS A WHOLE WITHOUT THE WRITTEN PERMISSION OF EGLASS LLC IS PROHIBITED.

NOTES: UNLESS OTHERWISE SPECIFIED		NAME	DATE	eGLASS RAILING™		
1. DIMENSIONS SHOWN - INCHES [MM]. 2. MACHINED SURFACES TO BE 63µIN MAX. 3. PART TO BE FREE OF BURRS AND SHARP EDGES. 4. ALL MATERIAL TO BE CLEAN, DEGREASED AND FREE OF ALL IMPURITIES. 5. ANY CHANGE MUST BE AUTHORIZED BY AN EGLASS ENGINEER.	DIMENSIONS ARE IN INCHES	DRAWN	V.P.	12/06/18	<b>TITLE: EGLASS VISION, FASCIA MOUNT, STAIR GUARD, WITH BRACKET, 36" RAILING SYSTEM</b>	
	FRACTIONAL ±	ENG APPR.				
	ANGULAR: MACH ±	MFG APPR.				
	TWO PLACE DECIMAL ±	COMMENTS:				
	THREE PLACE DECIMAL ±	PURCHASER HAS THE FULL RESPONSIBILITY TO COMPLY WITH LOCAL, NATIONAL AND INTERNATIONAL BUILDING CODES. PURCHASER SHALL COMPLY IN ALL RESPECTS WITH ALL APPLICABLE LEGAL REQUIREMENTS GOVERNING THE DUTIES, OBLIGATIONS, AND BUSINESS PRACTICES OF THEIR LOCALITIES AND SHALL OBTAIN ANY PERMITS OR LICENSES NECESSARY FOR THEIR OPERATIONS.			<b>SIZE A</b>	
MATERIAL	FINISH	DO NOT SCALE DRAWING		<b>DWG. NO. RVGS-00-00</b>	<b>REV 3</b>	
				SCALE: 1:50	WEIGHT:	SHEET 1 OF 2

2

1

2

1

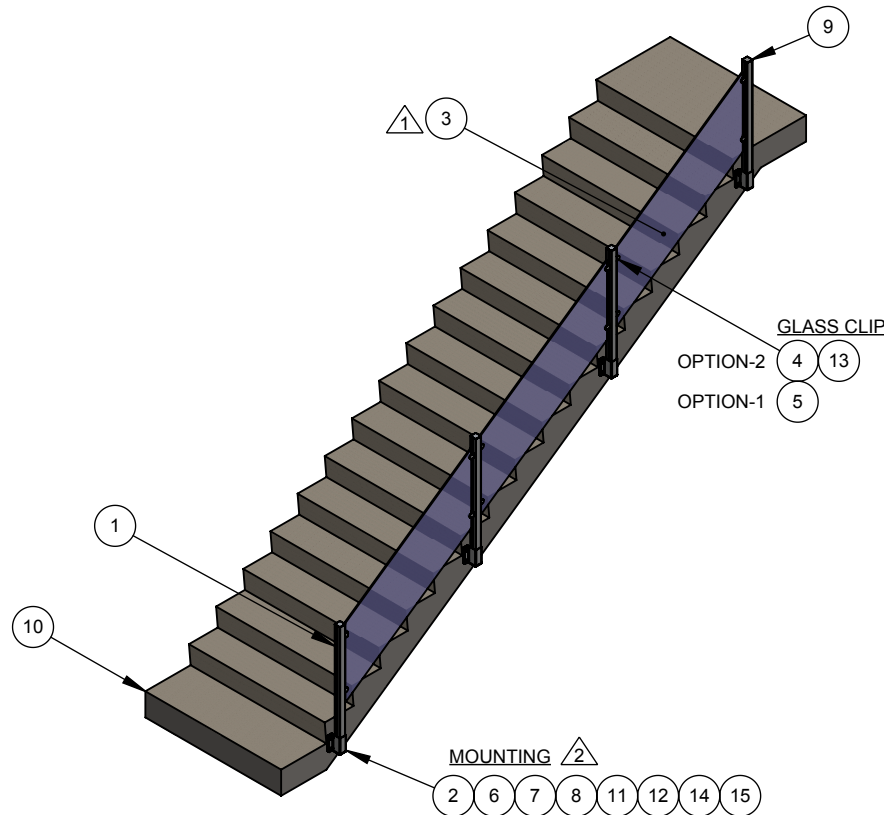

BILL OF MATERIAL TABLE			
ITEM NO.	PART NUMBER	DESCRIPTION	QTY.
1	AAFA-SP-56	SQUARE POST, LONG BLANK, (2 3/8" x 2 3/8" x 1/8" x 56")	AS REQD.
2	AAGA-IB-01	INTERMEDIATE FASCIA BRACKET, 6" HEIGHT	AS REQD.
3	RAAS-G3-08	3/8" TEMPERED GLASS, STAIR GUARD RAILING	AS REQD.
4	AVAA-GC-00	GLASS CLIP, ROUND	AS REQD.
5	AVAA-GC-20	FLAT SQUARE GLASS CLAMP	AS REQD.
6	AAGA-SH-01	SHIM STACK, INTERMEDIATE BRACKET	AS REQD.
7	AAGA-NG-01	NEOPRENE GASKET, INTERMEDIATE BRACKET	AS REQD.
8	AAGA-BC-01	BOTTOM CAP, INTERMEDIATE FASCIA BRACKET	AS REQD.
9	AAAA-PC-01	POST CAP, 2 3/8" SQUARE POST	AS REQD.
10	STD-DK-03	STEPS - CONCRETE	AS REQD.
11	STD-AC-06	3/8" THRU BOLT, 4" LG	AS REQD.
12	STD-SC-03	#10 x 3/4" PAN HEAD TEK SCREW	AS REQD.
13	STD-SC-07	#14 x 1 1/4" SMS	AS REQD.
14	STD-SC-09	#12 x 1" FLAT HEAD TF SCREW	AS REQD.
15	STD-SW-00	3/8" SCREW COVER	AS REQD.

NOTES:

- 1. DIFFERENT SIZES OF GLASS PANELS ARE AVAILABLE. REFER DWG NO: RAAS-G2-08 (1/4" THK) AND RAAS-G3-08 (3/8" THK).

2. MOUNTING:

INSIDE CORNER AND OUTSIDE CORNER BRACKETS:

FOR CONCRETE:

- 1. STD-AC-07 (3/8" THRU BOLT, 3.5" LENGTH)

FOR WOOD:

- 1. STD-AC-08 (5/8" LAG SCREW W/MIN 6" EMBED)

INTERMEDIATE BRACKETS:

FOR CONCRETE:

- 1. STD-AC-06 (3/8" THRU BOLT, 4" LENGTH)

FOR WOOD:

- 1. STD-AC-05 (3/8" LAG SCREW W/MIN 6" EMBED)

NOTES: UNLESS OTHERWISE SPECIFIED		NAME	DATE				
<p>1. DIMENSIONS SHOWN - INCHES [MM].</p> <p>2. MACHINED SURFACES TO BE 63uIN MAX.</p> <p>3. PART TO BE FREE OF BURRS AND SHARP EDGES.</p> <p>4. ALL MATERIAL TO BE CLEAN, DEGREASED AND FREE OF ALL IMPURITIES.</p> <p>5. ANY CHANGE MUST BE AUTHORIZED BY AN EGLASS ENGINEER.</p>	<p>DIMENSIONS ARE IN INCHES</p> <p>FRACTIONAL ±</p> <p>ANGULAR: MACH ±</p> <p>TWO PLACE DECIMAL ±</p> <p>THREE PLACE DECIMAL ±</p>	DRAWN	V.P.			12/06/18	<p>TITLE: <b>EGLASS VISION, FASCIA MOUNT, STAIR GUARD, WITH BRACKET, 36" RAILING SYSTEM</b></p>
	MATERIAL	COMMENTS:					
	FINISH	PURCHASER HAS THE FULL RESPONSIBILITY TO COMPLY WITH LOCAL, NATIONAL AND INTERNATIONAL BUILDING CODES. PURCHASER SHALL COMPLY IN ALL RESPECTS WITH ALL APPLICABLE LEGAL REQUIREMENTS GOVERNING THE DUTIES, OBLIGATIONS, AND BUSINESS PRACTICES OF THEIR LOCALITIES AND SHALL OBTAIN ANY PERMITS OR LICENSES NECESSARY FOR THEIR OPERATIONS.					
	DO NOT SCALE DRAWING	SIZE	DWG. NO.	REV			
		<b>A</b>	<b>RVGS-00-00</b>	<b>3</b>	SCALE: 1:60	WEIGHT:	SHEET 2 OF 2

eGlass Vision™

PROPRIETARY AND CONFIDENTIAL

THE INFORMATION CONTAINED IN THIS DRAWING IS THE SOLE PROPERTY OF EGLASS LLC. ANY REPRODUCTION IN PART OR AS A WHOLE WITHOUT THE WRITTEN PERMISSION OF EGLASS LLC IS PROHIBITED.

2

1