

2

1

B

B

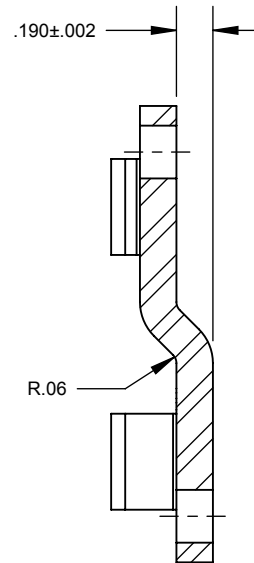
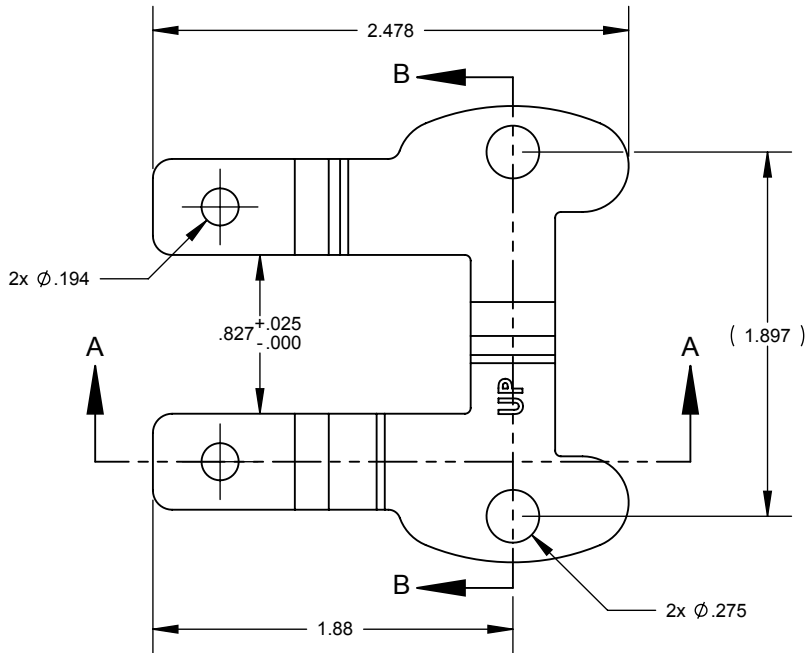

SECTION B-B

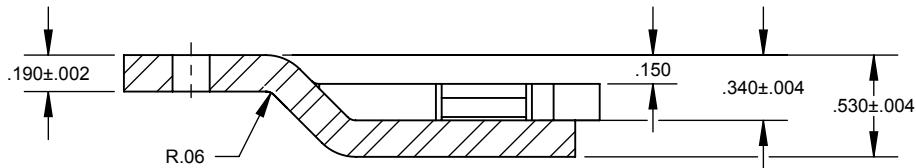
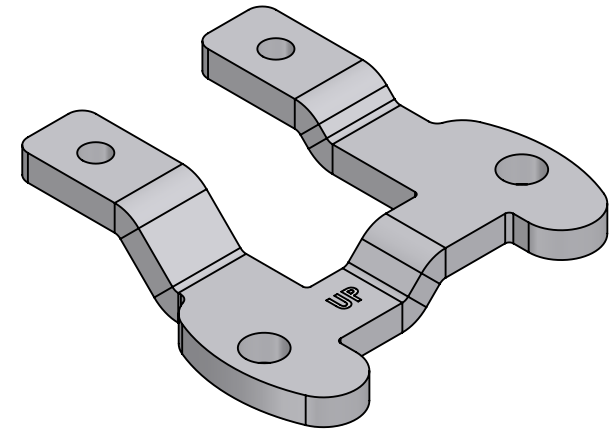

SECTION A-A

A

A

eGlass Solid™
eGlass Picket™

PROPRIETARY AND CONFIDENTIAL

THE INFORMATION CONTAINED IN THIS DRAWING IS THE SOLE PROPERTY OF EGLASS LLC. ANY REPRODUCTION IN PART OR AS A WHOLE WITHOUT THE WRITTEN PERMISSION OF EGLASS LLC IS PROHIBITED.

NOTES: UNLESS OTHERWISE SPECIFIED

1. DIMENSIONS SHOWN - INCHES [MM].
2. MACHINED SURFACES TO BE 63µIN MAX.
3. PART TO BE FREE OF BURRS AND SHARP EDGES.
4. ALL MATERIAL TO BE CLEAN, DEGREASED AND FREE OF ALL IMPURITIES.
5. ANY CHANGE MUST BE AUTHORIZED BY AN EGLASS ENGINEER.

DIMENSIONS ARE IN INCHES
FRACTIONAL ±
ANGULAR: MACH ±
TWO PLACE DECIMAL ±
THREE PLACE DECIMAL ±

MATERIAL
ADC 12 ALUMINUM ALLOY

FINISH

DO NOT SCALE DRAWING

NAME DATE
V.P. 08/13/19

DRAWN
ENG APPR.
MFG APPR.

COMMENTS:
PURCHASER HAS THE FULL RESPONSIBILITY TO COMPLY WITH LOCAL, NATIONAL AND INTERNATIONAL BUILDING CODES. PURCHASER SHALL COMPLY IN ALL RESPECTS WITH ALL APPLICABLE LEGAL REQUIREMENTS GOVERNING THE DUTIES, OBLIGATIONS, AND BUSINESS PRACTICES OF THEIR LOCALITIES AND SHALL OBTAIN ANY PERMITS OR LICENSES NECESSARY FOR THEIR OPERATIONS.



TITLE:
**EGLASS SOLID,
MOUNTING BRACKET**

SIZE A	DWG. NO. ASAA-MB-01	REV 6
------------------	-------------------------------	-----------------

SCALE: 1:1 | WEIGHT: 27.231 g | SHEET 1 OF 2

2

1

2

1

B

B

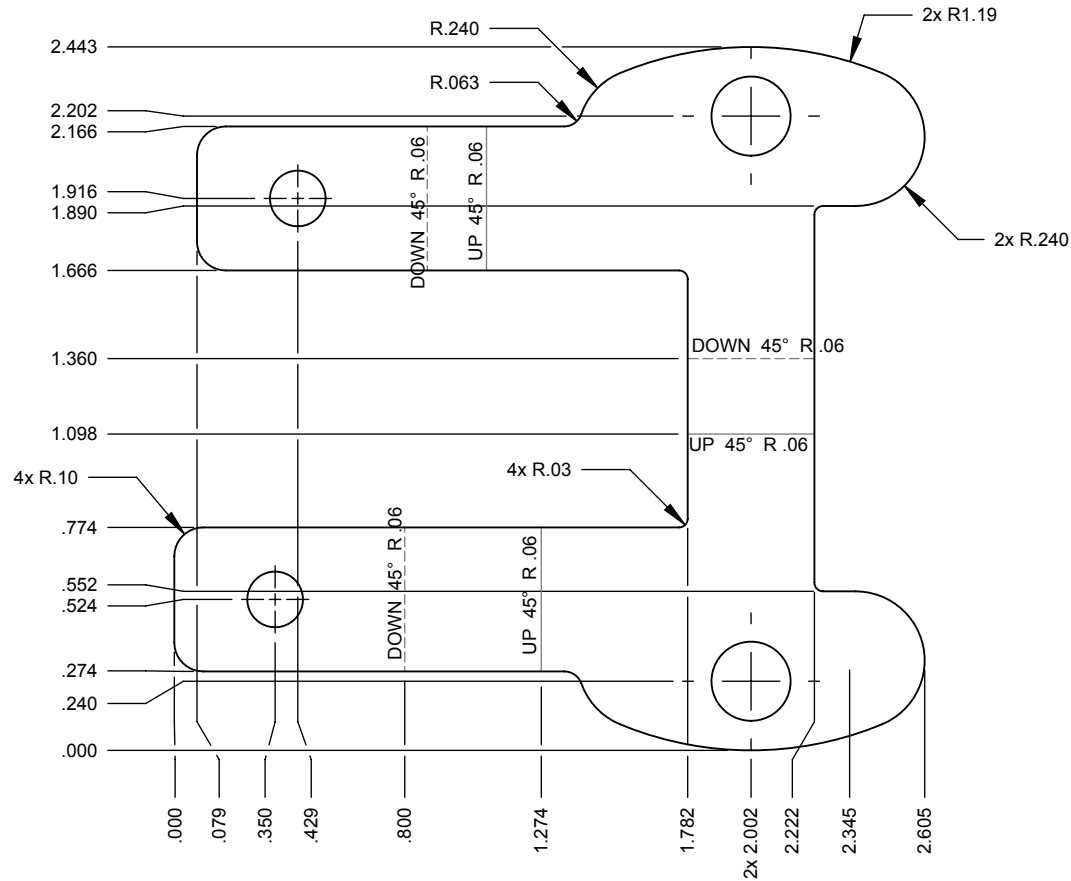

FLAT PATTERN

A

A

eGlass Solid™
eGlass Picket™

PROPRIETARY AND CONFIDENTIAL

THE INFORMATION CONTAINED IN THIS DRAWING IS THE SOLE PROPERTY OF EGLASS LLC. ANY REPRODUCTION IN PART OR AS A WHOLE WITHOUT THE WRITTEN PERMISSION OF EGLASS LLC IS PROHIBITED.

NOTES: UNLESS OTHERWISE SPECIFIED

1. DIMENSIONS SHOWN - INCHES [MM].
2. MACHINED SURFACES TO BE 63uIN MAX.
3. PART TO BE FREE OF BURRS AND SHARP EDGES.
4. ALL MATERIAL TO BE CLEAN, DEGREASED AND FREE OF ALL IMPURITIES.
5. ANY CHANGE MUST BE AUTHORIZED BY AN EGLASS ENGINEER.

DIMENSIONS ARE IN INCHES
FRACTIONAL ±
ANGULAR: MACH ±
TWO PLACE DECIMAL ±
THREE PLACE DECIMAL ±

MATERIAL
ADC 12 ALUMINUM ALLOY

FINISH

DO NOT SCALE DRAWING

	NAME	DATE
DRAWN	V.P.	08/13/19
ENG APPR.		
MFG APPR.		

COMMENTS:
PURCHASER HAS THE FULL RESPONSIBILITY TO COMPLY WITH LOCAL, NATIONAL AND INTERNATIONAL BUILDING CODES. PURCHASER SHALL COMPLY IN ALL RESPECTS WITH ALL APPLICABLE LEGAL REQUIREMENTS GOVERNING THE DUTIES, OBLIGATIONS, AND BUSINESS PRACTICES OF THEIR LOCALITIES AND SHALL OBTAIN ANY PERMITS OR LICENSES NECESSARY FOR THEIR OPERATIONS.



TITLE:
**EGLASS SOLID,
MOUNTING BRACKET**

SIZE	DWG. NO.	REV
A	ASAA-MB-01	6

SCALE: 3:2 | WEIGHT: 27.231 g | SHEET 2 OF 2

2

1