

2

1

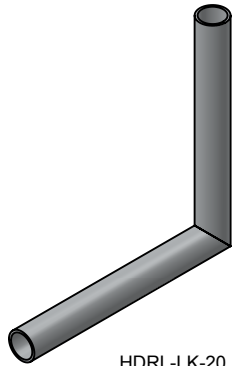

HDRL-LK-20
(NONE)



HDRL-LK-20-BL
(BLACK)

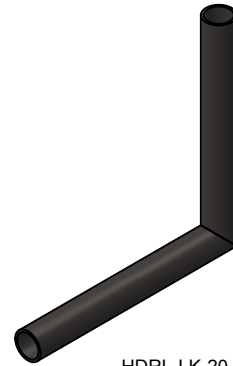

HDRL-LK-20-BZ
(BRONZE)

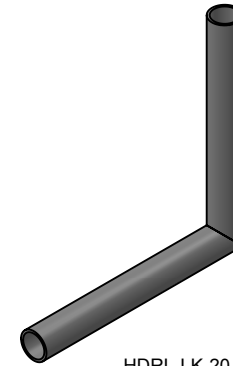

HDRL-LK-20-SL
(SILVER)

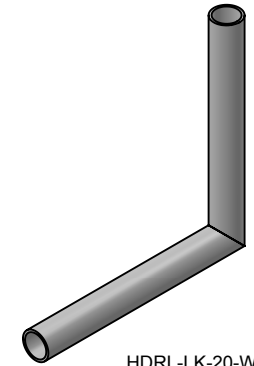

HDRL-LK-20-WT
(WHITE)

BILL OF MATERIAL TABLE			
ITEM NO.	PART NUMBER	DESCRIPTION	QTY.
1	HDRL-LK-21	LINK HANDRAIL 90° CORNER FOR Ø 1 1/2 TUBING	2

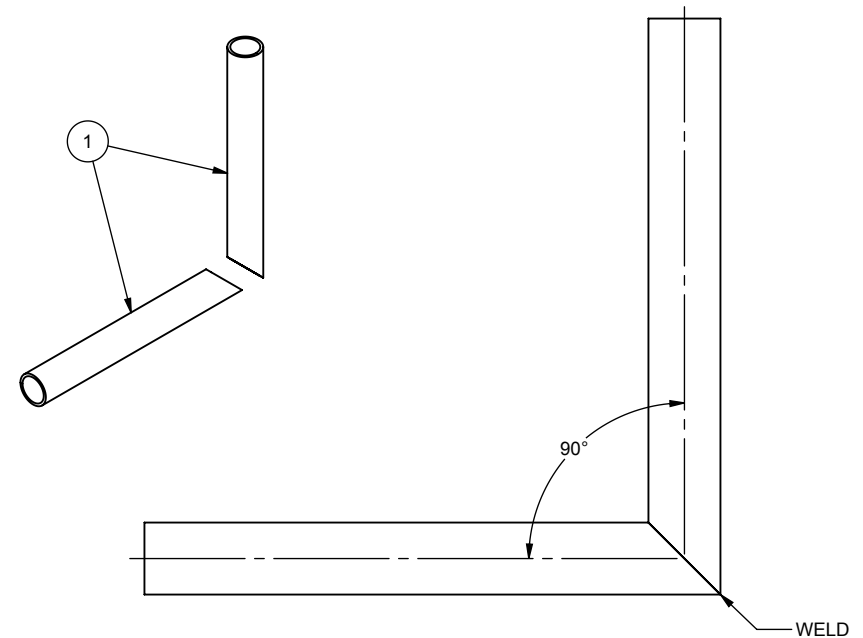
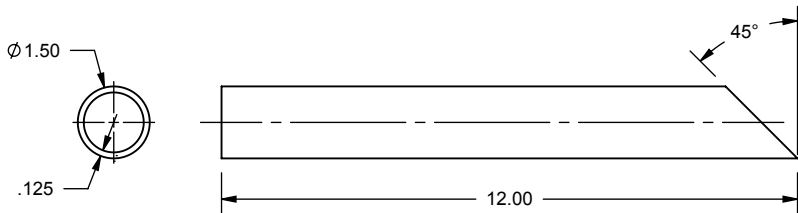

PART IS MADE FROM "HDRL-LK-00" EXTRUSION

<p>NOTES: UNLESS OTHERWISE SPECIFIED</p> <p>1. DIMENSIONS SHOWN - INCHES [MM]. 2. MACHINED SURFACES TO BE 63uIN MAX. 3. PART TO BE FREE OF BURRS AND SHARP EDGES. 4. ALL MATERIAL TO BE CLEAN, DEGREASED AND FREE OF ALL IMPURITIES. 5. ANY CHANGE MUST BE AUTHORIZED BY AN EGLASS ENGINEER.</p>		<p>DIMENSIONS ARE IN INCHES</p> <p>FRACTIONAL ± ANGULAR: MACH ± TWO PLACE DECIMAL ± THREE PLACE DECIMAL ±</p>		<p>NAME</p> <p>V.P.</p>	<p>DATE</p> <p>10/17/19</p>	<p>EGLASS RAILING™</p> <p>TITLE: LINK HANDRAIL 90° CORNER</p>	
		<p>MATERIAL</p> <p>AAMA 2605 POWDER COAT</p>	<p>FINISH</p> <p>AAMA 2605 POWDER COAT</p>	<p>COMMENTS:</p> <p>PURCHASER HAS THE FULL RESPONSIBILITY TO COMPLY WITH LOCAL, NATIONAL AND INTERNATIONAL BUILDING CODES. PURCHASER SHALL COMPLY IN ALL RESPECTS WITH ALL APPLICABLE LEGAL REQUIREMENTS GOVERNING THE DUTIES, OBLIGATIONS, AND BUSINESS PRACTICES OF THEIR LOCALITIES AND SHALL OBTAIN ANY PERMITS OR LICENSES NECESSARY FOR THEIR OPERATIONS.</p>			
<p>PROPRIETARY AND CONFIDENTIAL</p> <p>THE INFORMATION CONTAINED IN THIS DRAWING IS THE SOLE PROPERTY OF EGLASS LLC. ANY REPRODUCTION IN PART OR AS A WHOLE WITHOUT THE WRITTEN PERMISSION OF EGLASS LLC IS PROHIBITED.</p>		<p>DO NOT SCALE DRAWING</p>		<p>SCALE: 1:4</p>		<p>WEIGHT:</p>	<p>SHEET 1 OF 1</p>

2

1